

POWER LINE COMMUNICATION (PLC)

VER: 01, UPDATED ON JUNE 26TH, 2019

APPLICATION BACKGROUND

In solar system, communication is an important part, like WiFi, ALN, GPRS, Bluetooth, RS485 and PLC etc. And what is more important is to find a proper monitoring method base on different conditions. For example, PLC is normally used in big commercial or utility scale projects because of its cost-saving characters like saving communication cable cost and O&M and system installation cost comparing with RS485, and also its convenience and stability comparing with separated WiFi or LAN communications methods.

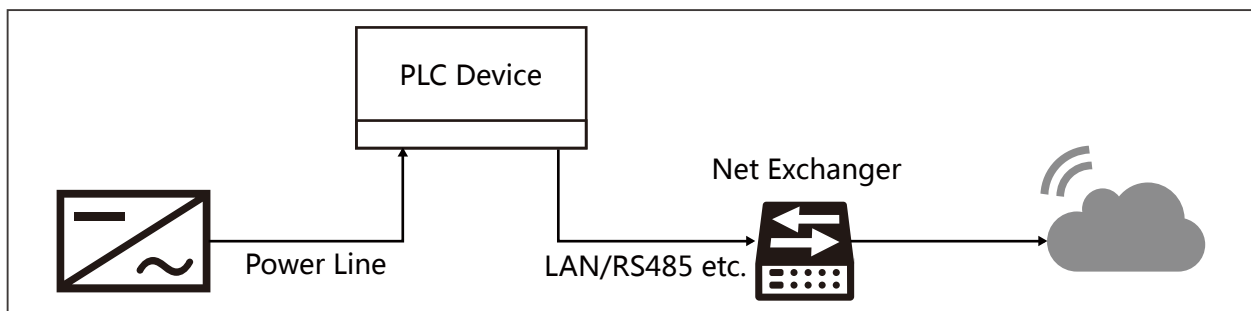

1. PLC is a way to use power line to transfer modulated carrier signals, which is added into a power line system and unscrambled at the end side.
2. Normally it is used in a load-less solar (before the signal is unscrambled) system.

GOODWE SOLUTIONS

• **DEVICE: SCB2000 Communication Box**



Teknik Özellikler		
MODEL		SCB2000
COMM.METHODS	TO INVERTER	PLC
	TO CLOUD	Lan/GPRS/OPTICAL FIBER
INVERTER CONNECTION NO.		30 pcs
MAX POWER LINE DISTANCE		1000 m
OTHER FUNCTIONS		Compatible with Weather Station or Other Third-Party Devices
POWER SUPPLY		230Vac, 50/60Hz

1. Compatible with GoodWe MT series inverters (50KW - 80KW)

SCB2000 integrated with PLC communication board, Datalogger board and Optical Fibre communication board together inside, is a specific solution for PLC communication requirement.

POWER LINE COMMUNICATION (PLC)

VER: 01, UPDATED ON JUNE 26TH, 2019

• **OVERALL WIRING DIAGRAMS**

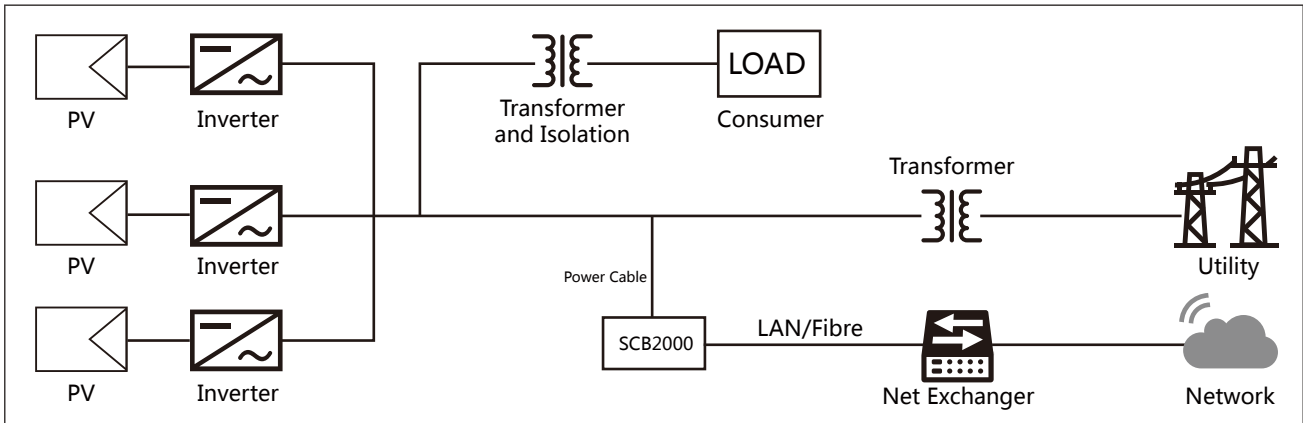

Diagram1 : Communicate to Network By LAN or Optical Fibre

1. On the low-voltage side of transformer system, if there is load consumption, the isolation transformer shall be adopted loads and PLC system

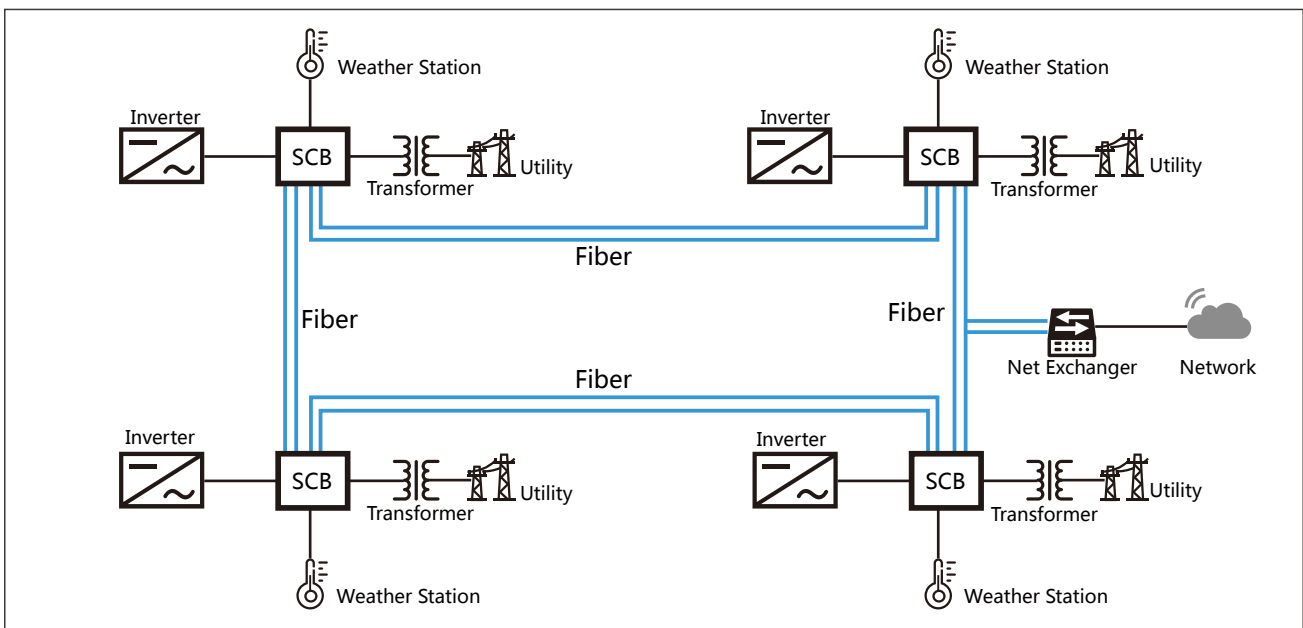

Diagram 2: Fiber Halka yonteminin uygulanişi

1. In a fibre ring system, one of the SCB 2000 devices must be set as master device, and the other units will be seen as slaves automatically(see below)
2. In fibre ring system, any network point loses connection, the system could continue with data transfer

Notice

The information in this document is subject to change without notice, all information in this document do not constitute any kind of warranty. Please check with GoodWe Solar Academy 'academy@goodwe.com' for the latest version.