



EOI NO. DNRE/ SOLAR INVERTER CHARGERS /2021-22/01

EXPRESSION OF INTEREST (EOI)

***FOR EMPANELMENT OF SUPPLIERS FOR SUPPLY, INSTALLATION &
COMMISSIONING
OF
320/640 W SOLAR INVERTER CHARGERS***

IN

HARYANA STATE

**DEPARTMENT OF NEW & RENEWABLE ENERGY, HARYANA
Akshay Urja Bhawan, Institutional Plot No. 1, Sector-17, Panchkula
PHONE: 0172-2585733, 2585433 EPBX: 0172-2587233, 2587833
Fax No.0172-2564433
Email: hareda@chd.nic.in Website: www.hareda.gov.in**

(Note this document contains 39 pages (1-39) including this page)

NEW & RENEWABLE ENERGY DEPARTMENT, HARYANA

Akshay Urja Bhawan, Sector-17, Panchkula

PHONE: 0172-2585733, 2585433 Fax No.0172-2564433

Email: hareda@chd.nic.in Website: www.hareda.gov.in

E-EOI NO. HAREDA/ SOLAR INVERTER CHARGERS /2021-22/01

NOTICE INVITING EOI

E-EOIs are invited for empanelment of firms for supply, installation and commissioning including warranty, maintenance for five years in the state of Haryana for below mentioned systems/ projects :-

S. No.	Description	Quantity	EOI fees + EMD+ e-Service fees (Rs.)	Expiry Date & Time of online EOI Preparation & Submission
1	320/640 Watt Solar Inverter Chargers	Approx. 38,726 nos. (34,411 nos. of 640 Watt and 4,315 nos. of 320 Watt-	5,000+ 2,00,000+ 1,000 (GST Rs.180/- extra)	17.06.2021- 2:00PM

1. The EOI Document's fee, EMD and E-Service will be paid online and last date of same will be 12.06.2021.
The EOI document having detailed terms and conditions can be downloaded from the portal <https://etenders.hry.nic.in> from 27.05.2021 from 10:00 Hrs onwards. The E-EOIs shall be received through portal only. All interested firms are requested to get themselves registered as vendors with the said portal for submitting their EOIs. For any assistance, please contact, For support related to Haryana Tenders in addition to helpdesk you may also contract to following:-
E -mail: eproc.nichry@yahoo.com
Desk: 0172-2700275
2. EOIs will be opened in the office of the Director General, New and Renewable Energy Department, Sector-17, Panchkula (Haryana) on **17.06.2021 at 3:00 Hrs.**
3. DNRE reserves the right to modify, amend or supplement this document including all formats and Annexures. DNRE also reserves the right to reject one or all the EOIs received, without assigning any reason.
4. Corrigendum, if any, would only be published online on the portal. Prospective firms are advised to update with the above website.

Director General,
New and Renewable Energy Department, Panchkula

Online Expression of Interest (EOI) are invited as per the details given below in Schedule-A

SCHEDULE-A

(Sr. No.)	PARTICULARS	REMARKS
1	Tender Notice No.	01/2021-2022
2	Sr. No. of Tender.	01
3	Superscribed No. of Tender.	01/HR/EM/SIC/2021-22
4	Online submission of EMD, Tender fee & e-Service Fee Option-1: Through Net Banking and Debit card	On or before last date of submission of Technical Bids upto 12:00 Noon
5	Online submission of EMD Option-2: Through RTGS/ NEFT- <i>(In case of above, the bidder has to pay Tender Fee & e-Service Fee Through Net Banking and Debit card as per the given date & time schedule)</i>	On or before 12.06.2021 Upto 02:00 P.M.
6	On line Bid Preparation & submission.	Upto 17.06.2021 at 02:00 P.M.
7	Date & time of opening of Technical Bids/s.	On or after 17.06.2021 at 02:30 P.M.
8	Date & time of Technical Committee meeting and opening of tentative price quoted	To be decided later on
9	Tender Fee:	
	(I) For Haryana based manufacturing Micro and Small Enterprises (MSEs) & Khadi Village Industries Unit eligible as per the "Haryana State Public Procurement Policy for MSME - 2016" notified vide G.O. No. 2/2/2016-4I BII(1) dated 20-10-2016 and as amended from time to time.	NIL
	(II) For Haryana based Startups/First Generation Entrepreneurs eligible as per State policy "Concession/benefits in Public Procurement to Startups/First Generation Entrepreneurs of State" issued vide G.O No.2/2/2016-4I B-II dated 03.01.2019.	NIL
	(III) For remaining bidders both from the Haryana and Non Haryana	Rs. 5000/-
10	Earnest Money Deposit (EMD) required:	
	(I) For Haryana based manufacturing Micro and Small Enterprises (MSEs) & Khadi Village Industries Unit eligible as per the "Haryana State Public Procurement Policy for MSME - 2016" notified vide G.O. No. 2/2/2016-4I BII(1) dated 20-10-2016 and as amended from time to time.	NIL
	(II) For Haryana based Startups/First Generation Entrepreneurs eligible as per State policy "Concession/benefits in Public Procurement	NIL

	to Startups/First Generation Entrepreneurs of State” issued vide G.O No.2/2/2016-4I B-II dated 03.01.2019.	
	(III) Central or Haryana Public Sector Enterprises and “approved sources” as declared by the Industries Department, Haryana	NIL
	(IV) For remaining bidders both from the Haryana and Non Haryana	2,00,000/-
11	E-Service Fee	Rs. 1000/-
12	Date and time of receipt of samples (if required)	N.A
13	Bids to be kept valid for acceptance upto:	31.12.2021

A. Information to Bidders:

The Bidders can download the tender documents from the Portal: <https://etenders.hry.nic.in>

1. Date and Time of making payment of tender fee, earnest money deposit (EMD) and e-service fee is as under:

A	Online submission of EMD, Tender fee & e-Service Fee Option-1: Through Net Banking and Debit card	On or before last date of submission of Technical Bids upto 12:00 Noon
B	Online submission of EMD Option-2: Through RTGS/ NEFT- <i>(In case of above, the bidder has to pay Tender fee & e-Service fee Through Net Banking and Debit card as per the given date & time schedule)</i>	On or before 12.06.2021 Upto 02:00 P.M.

2. As the Bids are to be submitted online and are required to be encrypted and digitally signed, the Bidders are advised to obtain Digital Signature Certificate (DSC) at the earliest. For obtaining Digital Certificate, the Bidders should follow Point No.- 2 under “Instructions to bidder on Electronic Tendering System” and available at the link: <https://etenders.hry.nic.in>
3. The Bidders shall have to pay for the Tender Documents Fee, EMD Fees & e-Service Fee online by using the service of secure electronic payment gateway. The secure electronic payments gateway is an online interface between bidders and online payment authorization networks.
4. The bidders must have Net Banking account in order to pay Tender Document Fee and e-Service Fee.
5. **Payment of Tender Fee:-** The payment for the Tender Document Fee shall be made by the interested bidder online directly through Net Banking with the available Banks at e-GRAS e-Payment Gateway.
6. **Payment of e-Service Fee:-** E-Service Fee payment shall be made separately by the interested bidders/ contractors online directly through Net Banking Account.
7. **Payment of EMD:-** The payment of EMD can be made through Net Banking or RTGS/ NEFT as per details at Para-3 above. In this regard please refer to ‘Online Payment Guideline’ available at the link: <https://etenders.hry.nic.in>
8. Intending bidders will be mandatorily required to sign-up online (create user account) on the website <https://etenders.hry.nic.in> to be eligible to participate in the e-Tender. In case the intended bidder fails to pay EMD fee under the stipulated time frame, he/she shall not be allowed to submit his/ her bids for the respective event/ Tenders.
9. In case of payment of EMD through RTGS/ NEFT, the interested bidders must remit the funds at least T+1 working day (Transaction + One Day) in advance i.e. on or before **12.06.2021 upto 2.00 P.M;** and make payment via RTGS/NEFT to the beneficiary account number specified under the online generated challan. The intended bidder/ Agency thereafter will be able to successfully verify their payment online, and submit their bids

on or before the expiry date & time of the respective events/ Tenders at <https://etenders.hry.nic.in>

10. However, the details of the EMD, Tender document Fee & E - Service Fee are required to be filled/ provided at the time of online Bid Preparation.
11. Online Technical Envelope—Reference details of the Earnest Money Deposit, Tender Document Fee & e - Service Fee instrument and scanned copies of supporting documents and QR/technical criteria with proper index and page numbering on all the documents have to be provided as per **Annexure-IA** of this document.
12. If the tenders are cancelled or recalled on any grounds, the Tender Document Fee and e-Service Fee will not be refunded to the bidder.

B. Brief Description of item:

Sr. No.	Description of Stores	Quantity	Place of Delivery
1	Supply, installation and commissioning of 320/640 Watt Solar Inverter Charger in the Haryana State with five years warranty of complete system.	Approx. 38,726 nos. (34,411 nos. of 640 Watt and 4,315 nos. of 320 Watt-	At beneficiaries households

New & Renewable Energy Department is implementing a scheme of Solar Inverter Charger to charge the batteries of existing conventional Inverter and to provide additional source of power in market mode. Under market mode, the beneficiaries have freedom to choose any supplier from the Department empanelled suppliers. The beneficiary share (Total cost of systems- applicable subsidy) shall be collected by empanelled supplier from beneficiaries and subsidy shall be released to supplier after installation and commissioning of system.

The detailed technical specification/ description of the above stores are available at **Annexure-I & II** of this document.

SCOPE OF WORK

Supply, installation & commissioning of Solar Chargers of capacity 320 watt/ 640 watt in market mode at various locations in the State of Haryana, as per the technical specifications given in annexure-I & II with five years warranty of the complete system(s) from the date of commissioned and PV modules used in the power plant must be warranted for their output peak watt capacity, which should not be less than 90% at the end of 10 years and 80% at the end of 25 years as per latest

The scope of work shall include the following:

- a. Supply, installation & commissioning of Solar Inverter Chargers of capacity 320 watt/ 640 watt. The Solar Inverter Charger consists of Solar PV Modules, Interface Charge Controller, connecting wires, structure & other mechanical as well as electric/ electronics components etc.
- b. Wiring up to the existing inverter from the Solar Panels will be in the scope of the

- bidder(s).
- c. Performance testing of the complete system.
 - d. The installer shall undertake to supply spares free of cost for the maintenance of the offered items during the warranty period.
 - e. After sales service , directly or through local service network
 - f. A leaflet containing the details of the service centers shall be provided to each purchaser as well as to New & Renewable Energy Department.
 - h. If the operation or use of the system proves to be unsatisfactory during the warranty period, the installer shall replace the faulty ones or carry out necessary repairs as per the warranty terms and conditions.

C. Specific Terms & Condition/ Eligibility Criteria related to above Store:

1. The Bidder should be either a body incorporated in India under the Companies Act, 1956 or 2013 including any amendment thereto or proprietary/partnership firm/LLP. A copy of certificate of incorporation shall be furnished along with the bid in support of above.
2. Bidder should be registered manufacturer of Solar Module or Solar Cells to be used in the quoted item.

OR

System Integrator

3. The System Integrator has to submit the undertaking (in Performa-VI) issued by each manufacturer of major parts/other devices (solar modules/Interface charge controller) with whom they have tie up mentioning that in case System Integrator defaults, at any stage of execution of warrantee/guarantee/CMC and after sale service of the said device, installed in reference to empanelment of the said EOI, then the Company will be responsible to execute the warrantee/guarantee/CMC of the said device at site of installation as per the terms and conditions of EOI of the above tender and will adhere the directions of the New & Renewable Energy Department/HAREDA directly.
4. The bidder has to submit BIS test certification of Solar Module and Test report of the remaining minor component i.e. Interface Solar Charge Controller & wire from the Original manufacturer issued by any of the MNRE / BIS /IEC/ NABL accredited laboratory on or after 01.04.2018. Bid without valid test report of Solar Module and Interface Solar Charge Controller & wire will be rejected out rightly. The make and test report of cable/wire must also be submitted with the bid. The bidder will submit tie-up certificate for component i.e. Solar Module, Interface Solar Charge Controller from the Original manufacturer.

Further, Only indigenously produced Solar PV modules with indigenously manufactured solar PV cells shall be allowed in PV array. The Solar Module must be comply with MNRE OM of even No. dated 02.01.2019 for enlistment under “Approved Models and Manufacturers of Solar Photovoltaic Modules (Requirement of Compulsory Registration) order, 2019 and its subsequent amendments at the time of supply. Further, the models and manufacturers of PV Modules shall be included in the List of Models and Manufacturers for Solar PV Modules empanelled by MNRE as per its ALMM order (and also valid at the time of supply of material) from time to time.

If the Manufacturers of PV Modules has applied to MNRE for including their models and name in the List of Models and Manufacturers for Solar PV Modules empanelled by MNRE in its ALMM order, then the bidder has to submit the acknowledgement for application for the same. In such cases if the name is not included in the said list as on the date of opening of financial bids/STC meeting, then the bidders will be treated as technically non-eligible (it is the responsibility of the bidder to submit the proof of inclusion of their models and name in the said list on or before the date of opening of financial bids/STC meeting).

To bring contractual clarity, Bidders has to give explicit declaration that they are aware of binding provisions of the ALMM Order and the List(s) there under, while quoting the rates in the bid.

5. The manufacturing firm should have a valid ISO 9001:2015 Certificate in the field of quoted item and copy of valid ISO 9001:2015 Certificate must be attached with offer.
6. Bidder should have not been debarred/blacklisted by any Govt. Deptt's / organization/ PSU's / institutions/ agencies/ autonomous Organizations. Submit a Affidavit duly attested by the notary.
7. The Bidder should have valid GST registration certificate of the billing state and PAN number. A copy of which should be enclosed.
8. The Successful Bidder shall be required to establish at least one Service Centre at Divisional Level in their area of operation in Haryana. The successful bidder should maintain the inventory of required spare parts at the service centre(s).
9. Past performance of the firms shall be considered while evaluating the technical bids. If the bidder has poor record for providing after sales services to the Haryana during last five years than their bid may be rejected out rightly.
10. The bidder should have minimum average annual turnover of Rs. 28.00 Cr. in the last three years, ending 31st March of the previous Financial Year i.e. upto 2020-21 duly certified by Chartered Accountant.
11. Experience and Past Performance of having successfully completed similar contracts i.e. Solar Home Light System/Solar Street Light/Solar Inverter Charger/Off Grid Solar Power plant costing not less than the amount equal to Rs. 37.34 Cr of the bid quantity during last 3 years upto last date of bid submission to Govt. / Semi Govt. Organizations duly certified by competent authority. This should be supported by work order & performance Certificate /JCR issued by Govt. Deptt./Agency.
12. The bidder should have positive net worth in the last three years, ending 31st March of the previous Financial Year. i.e. upto 31.03.21
13. Bidders should provide an undertaking that after the expiry of warranty period, they will provide necessary spare and services for the maintenance of items up to the period of additional five years.
14. Technical Catalogue of the product is required to be submitted along with the bid & same should be available on bidder's website.
15. All technically eligible bidders shall be empanelled. The EOI process is for empanelment of firms for tentative 38,726 nos. of 320/ 640W Solar Inverter Chargers at various locations in the state of Haryana, India. However, total nos./

capacity as indicated above may go up to 1.5 times of indented nos./ capacity, if required. Successful firms will have to unconditionally agree to the additional quantum beyond the indented nos./ capacity under the same terms and conditions. The Empanelment will be made / valid for one year from the date of issue.

16. The indicative rates given by bidders should be inclusive of GST and all other charges etc. (whichever applicable).
17. Delivery period (includes supply, installation & commissioning):- One months from the date of placement of work order by individual beneficiary.
18. Warranty: - Five years from the date of commissioning and PV module(s) will be warranted for a minimum period of 25 years from the date of supply. PV modules used in Solar Inverter Charger must be warranted for their output peak watt capacity, which should not be less than 90% at the end of Ten (10) years and 80% at the end of Twenty five (25) years.
19. Claim of Subsidy :- Subsidy amount @ Rs. 10,000/- for 640 Watt and Rs. 6,000/- for 320 Watt Solar Inverter Charger shall be released to supplier by HQ, DNRE after satisfactory installation / working of the items on submission of Project Completion Report (PCR) in the requisite format duly signed by the user & PO/APO of the consignee department/ office and User. The balance amount i.e. beneficiary share (Total cost of systems- applicable subsidy) shall be collected by empanelled supplier from beneficiaries.
20. The empanelled suppliers have to submit the Performance security Deposit for 5 years as required in EOI as per applicable guidelines of Supply and Disposal, Haryana. Additionally, the empanelled supplier has to submit the 20% of applicable Performance security Deposit as performance guarantee for performance of solar module valid for 25 years in the DNRE office.
21. Material shall be strictly as per DNIT specifications/requirement. The solar module must be BIS certified as per MNRE notification called the Solar Photovoltaics, Systems, Devices and Components Goods (Requirements for Compulsory Registration) Order, 2017 dated 05.09.2017 and its subsequent amendments. If there is any left out specification, the same shall be considered as per the latest specification/requirements applicable as per BIS/International Standards. The bidders are advised to be well conversant with these specifications/requirements for their compliance.
22. The make of components of the system i.e. Solar module, Interface Solar Charger controller, Cable/wire should be strictly as per test report submitted with the bid. The make and test report of cable/wire must also be submitted with the bid. The bidders can submit multiple make and test report of Solar Module, Interface Solar Charge Controller and Cable/Wires. Accordingly, the same should be mentioned in the technical bid.
23. The applicable GST will be 8.9% as mentioned in the Govt. of India, Ministry of Finance Amendments, Notification No. 25/2018- Integrated Tax (Rate) and Notification No. 24/2018- Central Tax (Rate), Dated- 31st Dec. 2018 Section- B (vii), goods specified in entry S.No. 234 i.e. Solar Power Based Devices or Solar Power Generating System, are supplied with other goods and services then the value of goods shall be deemed as seventy Percent of the gross consideration charged for all such supplies i.e. to be charged at 5% GST , and the remaining thirty percent of the gross consideration charged shall be deemed as value of the said taxable services i.e. to be charged at 18% GST, thus amounting to an overall tax rate of 8.9%. Further, if any change /amendment in thereof, same will be applicable.

24. Under no circumstances will a father or his son or their close relation or the partner of one firm be allowed to tender as separate tender. A breach of this condition will cause the tenders of such parties liable for rejection, forfeiture of their earnest money and the firm may be black listed.
25. The firm (s) tendering shall clearly mention in their tender whether any of the close/near relative of their management/ management of sister concerned firms is in the employment of the HAREDA/Department of New & Renewable Energy, Haryana and in case their close/near relative is in employment of the HAREDA/Department of New & Renewable Energy, Haryana then his/her name, designation and place of posting to be mentioned.
If the tendering firm not disclose and furnish the correct information as required in above clause, then his earnest money and/or Performance Security Deposit may be forfeited and in case the contractor has been awarded the work, the same may be cancelled. For concealing any information the firm may be black listed.

Note:

The word “Close/Near Relative” mentioned in the above clause means father, mother, brother, sister, brother-in-law, sister-in-law, daughter-in-law, daughter, father-in-law, mother-in-law, son, son-in-law, first cousin of self/spouse, spouse, father-in-law and mother-in-law of son/daughter.

26. Bidder who is manufacturer of Solar PV Modules or Solar Cells and manufacturing the said item (s) in its unit and having valid test report of, tested as per MNRE, GOI latest guidelines/BIS for minimal technical specifications of the tender document in its own name (the bidder) issued by MNRE/NABL/IEC accredited testing centres shall be treated as manufacturer being major and principal part manufacturer for getting the benefits of concession under MSME policy. The test report shall be issued by the date of closing the tender and shall be valid as on date of opening of the technical bid. The bidder shall have manufacturing facility of the said item, with testing facility, it in unit.
27. Bidder/firm having common director with the bidder should have not been debarred/blacklisted by any Govt. Deptt's/ Organization/PSU's/ institutions/agencies/autonomous Organization's/Ministry of Corporate Affairs.
28. If any bidder provides false information or conceals the facts regarding debarred/blacklisted, experience, turnover or other conditions mentioned in this tender, Nodal agency reserves the right to forfeit both EMD & Performance Bank Guarantee of the bidder, to black list the bidders, to cancel the contract and other punitive action.

Note: The format of the Technical Bid/ Index for the Technical Bid Documents will be as per Annexure-IA of this document and the bidders are requested to upload their Technical Bids on the Portal with index as provided in Annexure-IA.

In case of non submission of required Eligibility Documents as at Annexure-IA, the bid of the firm will not be considered and no further chance will be given for the submission of these documents. However, clarification, if any, of already submitted documents may be obtained in case required as per the rules.

D. **GUIDELINES FOR IMPLEMENTATION OF SOLAR INVERTER CHARGER SCHEME:-**

1. **Scheme:-**

The Solar Inverter Charger consist solar panels and interface charge controller, it used for charging the battery of existing conventional inverter during day time. Presently, two models of Solar Inverter Charger:-

Solar inverter of 320 Watt capacity:-It consists of solar panels of total 320 watt capacity and interface charge controller of 20 Amp. The system shall be installed on the existing conventional inverter of 600-800 VA having single battery of 12V DC x 120-180 AH.

Solar inverters of 640 Watt capacity:-It consists of solar panels of total 640 watt capacity and interface charge controller of 40Amp. The system shall be installed on the existing conventional inverter of 1000- 1800 VA having double battery of 12V DC x 120-180 AH to form the 24 VDC battery bank.

2. **Objective:-**

- i. To charge the battery bank of existing inverter from Solar Power thus availability of power during long power cuts.
- ii. To serve as back up during power cuts.
- iii. To generate electricity from clean and green energy which lead to saving of grid power in charging the batteries of inverter.
- iv. DC power generated from Solar is converted into AC by the inverter and used to run domestic applications along with battery power during power cuts.
- v. For Effective utilization of existing inverter in generation and utilization of clean and green energy.

3. **Implementation Methodology:-**

- The scheme shall be implemented in the market mode system means the beneficiaries will have freedom to choose any supplier from the DNRE empanelled supplier for said item. The list of empanelled suppliers will be available at the time of applying online on SARAL portal.
- The system shall be installed strictly meeting out the minimum technical specifications prescribed by New & Renewable Energy Department. The system with deviation and not meeting these minimum technical specifications will not be considered eligible for State Subsidy.
- The beneficiary has to pay only his share to supplier. The fixed subsidy @ Rs. 6,000/- and @ Rs. 10,000/- per system for 320 Watt and 640 watt Solar Inverter Charger respectively shall be provided to supplier after complete inspection of installed system by Concerned ADC.

4. **Empanelment of Suppliers:-**

All the technically qualified bidders will be empanelled. The successful bidders have to submit required Performance Security deposit as per policy of government. The list of empanelled suppliers will be made available at the time of applying at SARAL portal so that applicant can select any supplier. Further, the list of empanelled suppliers and Minimum Technical Specifications will also available on website of New & Renewable Energy Department at www.hareda.gov.in so that applicant can install from any supplier.

5. Eligibility of Beneficiaries:-

- i. Any Haryana resident family with Pariwar Pahichan Patra (PPP) will be eligible to apply.
- ii. All the households who have domestic inverter and not installed solar inverter charger on this existing inverter are eligible for this scheme on first come first serve basis.
- iii. The applicant should not have installed Solar Inverter Charger in past 5 years under the Departments Scheme.

6. Identification of Beneficiaries and Implementation Process :-

- i. The beneficiaries will be identified online on SARAL portal as per eligibility criteria. For this online application will be sought on SARAL portal form beneficiaries. Vide publicity is to done to sought applications.
- ii. The sanction letter will be issued to the eligible beneficiary on first come first serve basis to install the said items within 2 months as per DNRE specifications from DNRE empanelled suppliers. Thereafter, the sanction shall be automatically cancelled. The beneficiaries can download sanction letter from DNRE web portal.
- iii. The selected beneficiaries shall have to install said system from any DNRE empanelled firms as per the DNRE technical specifications. The plant not installed from the New & Renewable Energy Department empanelled supplier and not as per prescribed minimum technical specifications shall not be eligible for the subsidy.

7. Disbursement of Subsidy:-

- The subsidy @ Rs. 6,000/- and @ Rs. 10,000/- per system for 320 Watt and 640 watt Solar Inverter Charger respectively shall be released by the HQ to the supplier after inspection of installed system by respective ADC Office.
- The applicant has to make his share payment to the supplier on the mutual agreed terms and conditions between user and the supplier after mutual negotiation. DNRE will not be responsible for any dispute between user & supplier for beneficiary share.
- After installation of the system, the applicant has to submit Subsidy Claim form online at DNRE web portal for the claim of State subsidy along with required documents mentioned below:
 - i. Invoice of the supplier in the name of applicant
 - li Photographs of installed systems.
 - iii Project Completion Report in prescribed format.
 - iv The month and year of manufacturing of solar module and interface charge controller to be used in said system shall also be sought and it should be of not older than date of allocation of said item to the concerned beneficiary. The DNRE logo and make in India logo shall be laminated inside solar module and pasted on interface charge controller.
- After receiving the online application in the O/o Additional deputy Commissioner cum chief Project officer, DRDA, of the concerned district, the system shall be physically inspected by the concerned District Project Officer and shall issue Project Completion Report (PCR) in the prescribed format and upload the same on portal and verified the system on portal.
- After verification by ADC office, the online application shall be received to HQ. Thereafter, the State subsidy shall be released to supplier by HQ fortnightly basis.
- After sales services will be provided by the supplier during warranty period of 5 years as per term and conditions of tender.

E. Standard Terms and Conditions (wherever applicable these terms & conditions will overrule the specific terms and conditions as at Para 'C' above. Further, all the referred instruction here can be downloaded from website of Supplies and disposal, Haryana. All bidders are advised to read said instructions and submit the bid strictly as per said instructions):-

1. EMD:-

The firms are required to deposit Earnest Money as indicated above failing which the tenders are liable to be rejected. Manufacturing Micro & Small Enterprises (MSEs) of the State, Central or Haryana Public Sector Enterprises, "approved sources" as declared by the Industries Department, Haryana, and Startups/First Generation Entrepreneurs are exempt from the deposit of EMD. The condition at Sr. No. 7 of "Instructions to Tenderers of the TENDER FORM" shall be deemed to be amended to this extent as per provisions contained at Para 13 (i) (ii) of G.O. No.2/2/2010-4I-BII of dated 28.05.2010 and Para no 3(A)(ii) of G.O. No. 2/2/2016-4I BII (1) of dated 20.10.2016 (or as amended from time to time in this regard). The EMD of unsuccessful bidder shall be refunded after finalisation of empanelment of bidders and successful bidder after submission of required initial PSD.

2. Performance Security:

The successful bidders shall be required to deposit Performance Security Deposit (PSD) as per provisions contained in Govt. of Haryana G.O. No. 2/2/2016-4I BII(2) dated 20-10-2016 and its amendment vide order no. 8780-8959 dated 14.12.2020 as under:-

Sr. No.	Type of Firm/Enterprises	Value of Performance Security Deposit
1	Haryana based firms:- (i) # Haryana Based Micro and Small Enterprises (MSEs) (ii) Haryana based other firms/enterprises	(i) @0.2% of the estimated value i.e. Rs.48,240/- per 1000 systems (ii) @2% of the estimated value i.e. Rs.4,82,400/- per 1000 systems
	Other States/ UTs based firms (General Bidder)	@3% of the estimated value i.e. Rs.7,23,600/- per 1000 systems

Haryana based MSEs will be eligible for performance security deposit @ 0.2% who have filed SSI certificate/EM Part-II/Udyog Aadhar Memorandum/Udyam Registration (Micro or Small Enterprise category) in Haryana and who participate directly in the tendered/quoted items and offering to supply the entire quoted quantity from their own Haryana based unit.

Once supplier installs 1000 systems then PSD will be increased by same amount for each 1000 numbers. The PSD shall be released on successful completion of the warrantee period of five years from the date of commissioning of the project. If required, the validity of the SD/PSD will be extended by the firm failing which it will be en-cashed. The Performance Security shall be denominated in the currency of the Country, and shall be in form of a Bank guarantee, issued by a Nationalized/ Commercial bank located in the purchaser's country, acceptable to the Purchaser, in the form provided in the EOI Documents or Demand Draft in favour of Director General, HAREDA, payable at Panchkula.

3. **Concession/benefits to MSMEs of State:** The Government has notified “Haryana State Public Procurement Policy for MSME -2016” vide G.O. No. 2/2/2016-4I BII(1) dated 20-10-2016 and amendment vide G.O. No. 2/2/2016-4IB-II dated 11.12.2019 which will be applicable in respect of concessions to Haryana based MSMEs and KVIs. For claiming the relevant concession/s like Tender Fee, Earnest Money Deposit (EMD), Turnover, Exemption in respect of Past Performance & Experience, Purchase Preference and Performance Security, the bidders are required to submit the documentary proof from Government authorities showing that they come under Haryana based manufacturing MSME/KVI units as the case may be e.g. *Entrepreneurs/Udhayog Aadhar Memoranda/Udayam Registration in Haryana in bidder’s name and further subject to fulfillment of eligibility criteria/ document submitted as provided in the said Policy of 2016.
4. **Concession/benefits to Startups/First Generation Entrepreneurs of State:** The State Government has notified “Concession/benefits in Public Procurement to Startups/First Generation Entrepreneurs of State” issued vide G.O. No. 2/2/2016-4I B-II dated 03.01.2019 which will be applicable in respect of concessions to Startups/First Generation Entrepreneurs of State. For claiming the relevant concession/s like Tender Fee, Earnest Money Deposit (EMD), Turnover, Exemption in respect of Past Performance & Experience, Purchase Preference and Performance Security, the bidders are required to submit the documentary proof as per the said policy.
5. In case of evidence of cartel formation by the bidder(s), the EMD is liable to be forfeited along with other actions as are permissible to Government like filing complaints with the Competition Commission of India and/ or other appropriate forums.
6. **Grievance Redressal Mechanism for dealing with the representations/ complaints/ letters of the participating bidders/ firms:**
A time bound Grievance Redressal Mechanism for dealing with the representations/ complaints/ letters of the participating bidders/ firms in the tendering process in the State Public Procurement will be governed by State Government Policy issued vide G.O No.2/2/2016-4I-B II of dated 25.07.2016. All the bidders/ firms who want to make any representation/ complaint against any issue related to their technical scrutiny of the bids may do the same within 5 working days (up to 05:00 P.M. of the Fifth Working day) of the date of issue of letter/ intimation regarding their **As per NIT/ Not as per NIT status**. They have to ensure that their communication is delivered/ reached within 5 working days and delay in postal will not be counted as a valid reason. No representation/ complaint in whatsoever manner from the bidders/ firms will be entertained after the opening of Financial Bid.

7. Arbitration Clause

If any question, dispute or difference what so ever shall arises between DNRE and the contractor, in the connection with this agreement except as to matters, the decisions for which have been specifically provided, either party may forthwith give to the other notice in writing of existence of such question, dispute or difference and the same shall be referred to the sole arbitration of the Principal Secretary, Govt. Haryana, New & Renewable Energy Department or a person nominated by him/her. This reference shall be governed by the Indian Arbitration Act, and the rules made there under. The award in such arbitration shall be final and binding on both the parties. Work under the agreement shall be continuing during the arbitration proceedings unless the DNRE or the arbitrator directs otherwise.

8. Jurisdiction

All disputes will be settled within the jurisdiction of the Head Quarters of Director General, New & Renewable Energy, Haryana at Panchkula.

9. Warranty

- (i) The Warranty period shall be five (5) years for complete system from the date of commissioning and handing over of the system (or as per latest MNRE, Gol guidelines). The contractor shall rectify defects developed in the system within Warranty period promptly.
- (ii) During the warrantee period, the firm shall ensure proper functioning of the systems and complaint, if any, forwarded to the supplier against the system, will have to be attended within 72 hours of forwarding such complaints.
The complaints would be logged by the Department officers by e-mail/ fax in order to keep the proper delivery records. Further in case of failure to do so, penalty @ 0.1 % of the system cost per day (subject to max. 10% of the cost) after expiry of 72 hours shall be imposed. If the firm does not attend the complaint within the max penalty period then the system may be got repaired/ replaced from the performance security amount. In case whole performance security amount is utilized and complaint/s are still pending then an online / registered notice will be sent to the firm to attend the complaint and if failed to attend the complaint within 7 days then firm may be blacklisted and a legal proceedings may be initiated against the firm for breach the agreement.
- (iii) If the firm still does not attend the complaint within the above mentioned period then the firm may be blacklisted and a legal proceeding may be initiated against the firm for Breach the agreement.
- (iv) The supplier shall affirm as per standards for quality that anything to be furnished shall be new, free from all defects and faults in material, workmanship and manufacture, shall be of the highest grade and consistent with established and generally accepted standards for material of the type ordered, shall be in full conformity with the specifications, drawing or samples, if any and shall if operable, operate properly.
- (v) Performance of Equipment: In addition to the warranty as already provided, the supplier shall guarantee satisfactory performance of the equipment and shall be responsible for the period or up to the date specified in sub-clause (iii) hereof after the equipment has been accepted by the DNRE or indenting organisation to the extent for any defects that may develop such defects shall be removed at his own cost when called upon to do so by the DNRE or indenting organization.
- (vi) DNRE/the consignee will have the liberty to get the sample for the item(s) supplied tested from any of the Govt. approved laboratory at any time during the installation or warranty period to ascertain the performance of the item(s) as per DNIT specifications. The cost of testing will be borne by the supplier. If during the lab test, sample fails then supplier has to repair/ replace the defective systems within 15 days of issue of such notice. If on the request of the supplier more than one samples are drawn for lab test and any one of them fail the lab test, bidder has to replace all the defective system at his own cost.
- (vii) The Contractor in consultation with concerned Project Officer will conduct training programme for users, focusing on main features, operation and maintenance of the systems. After successful supply/commissioning of the system and training, the system will be handed over to the person designated by the end user.

- (viii) The Contractor/supplier shall continue to provide spare parts for 2 years after the expiry of warranty period at the users cost. If the contractor fails to continue to supply spare parts and services to users then DNRE shall take appropriate action against the firm which can be to ban the supplier for participating in future tenders of the DNRE.
- (ix) **Service Centers:** Each successful bidder (either from Haryana or outside Haryana) will have to establish at least one service centre at the divisional level in their area of operation in the State, where a skilled technician and readily available spare parts will be made available during the entire period of Warranty/ Guarantee. The supplier will convey name & address of the outlet along with name of contact person, his/ her address, mobile number & e-mail address within 90 days of placing of the work order to the Director General, DNRE or indenting organization. The name & address of the service outlet and contact number will be displayed on the web portal of DNRE at www.hareda.gov.in.
- (x) **Suryamitra:** There is a Programme under MNRE to provide training to ITI Certificate and Diploma holders on operation and maintenance of SPV devices and systems and it is called “Suryamitra Skill Development Programme”. The successful contractor(s) may preferably engage them in their service centers to provide necessary repairs and maintenance service including installation of the systems during the time of execution.
- (xi) **Monitoring Mechanism:** The project will be implemented under the overall supervision of New & Renewable Energy Department. For proper implementation of the scheme, 100% monitoring of systems shall be done by the concerned Project Officer of the district. The 10% monitoring of the scheme may also be done by the representative of Directorate office, on random basis. The monitoring of the systems can also be entrusted to third party.

F. OTHER TERMS AND CONDITIONS

1. The firms are required to mention bifurcation of their rates showing the detail of Basic Rates, GST, Duties etc. in their bid.
2. All documents to be submitted by the tenderers with their offer should be self-attested in case the same are copies of original documents.
3. The Earnest money of the tenderers will be forfeited to Govt. account and blacklisting/ debarring besides other penal action, if they withdraw their offer/ rates or modify the terms & conditions of the same at any time during the validity of their offer before acceptance.
4. The Bid i.e. Technical Bid as well as Financial Bid is to be submitted online on web portal <https://etenders.gov.in/eprocure/app>. The Technical Bids uploaded on the portal should have proper indexing and page numbering on all the documents forming the Technical bid.
5. The Financial bid/s of only those bidders/ items will be opened who qualify on the basis of their Technical Bids. The date & time of opening of the financial bids will be intimated in the due course.
6. The offer without prescribed earnest Money, tender Fee & E-Service fee is liable to be summarily rejected. The deficiency in the remaining documents and tender requirement can be made subject to the rules in this regard and decision by Director General, New & Renewable Energy Department, Haryana, Panchkula
7. The quantity of Stores can be increased or decreased.
8. Notwithstanding anything contained in the Tender, , New & Renewable Energy Department Haryana reserves the right to accept or reject any Bid, and to cancel the bid process and reject the Tender, at any time, without thereby incurring any liability to the

affected Bidder or Bidders and without any obligation to inform the participating/affected Bidder (s) the reason for such decision.

9. **Instructions to bidder on Electronic Tendering System.**

Registration of bidders on e-Procurement Portal, Information about Digital Certificate, Instructions about Online Payment of Tender Document fee/e-Service Fee/Earnest Money, Important Instructions & Help manual for online bidding and other General issues option available on Home page of NIC e-procurement portal i.e <https://etenders.hry.nic.in>.

In case bidders need any clarifications or if training required participating in online tenders they can contact office Timings of Help-desk support & Contract Details:-

The detail may be seen under “ Contract US” option available on Home Page of NIC e-Procurement portal i.e <https://etenders.hry.nic.in>.

For support related to Haryana Tenders in addition to Helpdesk:-

In addition, For support related to Haryana Tenders in addition to helpdesk you may also contract to following:-

E -mail: eproc.nichry@yahoo.com

Desk: 0172-2700275

The detailed Specifications of the Store items as mentioned in Para B of the Schedule-A/NIT are as under:-

TECHNICAL SPECIFICATIONS OF 320 WATT SOLAR CHARGERS WITH INTERFACE CHARGE CONTROLLER TO CHARGE THE BATTERIES OF EXISTING DOMESTIC INVERTORS

Item	Description
CAPACITY	320 Watt small solar power pack to charge the batteries of existing domestic inverters.
SPV Module	<ul style="list-style-type: none"> • The Photovoltaic module should be Mono/ poly crystalline. • The Photovoltaic modules must be BIS certified as per IS 14286 and in addition modules must confirm to IS/IEC 61730-1 requirement for construction and part-2 requirement for testing, for safety qualifications. The supplier shall provide performance guarantee for the PV modules used in the power plant must be warranted for their output peak watt capacity, which should not be less than 90% at the end of 10 years and 80% at the end of 25 years. • The efficiency of the PV modules should be minimum 15% and fill factor should be more than 70%. • Only indigenously produced PV modules with indigenously manufactured solar PV cells shall be allowed in PV array. The Solar Module must be comply with MNRE OM of even No. dated 02.01.2019 for enlistment under “Approved Models and Manufacturers of Solar Photovoltaic Modules (Requirement of Compulsory Registration) order, 2019 and its subsequent amendments at the time of supply. Further, the models and manufacturers of PV Modules shall be included in the List of Models and Manufacturers for Solar PV Modules empanelled by MNRE as per its ALMM order (and also valid at the time of supply of material) from time to time. • If the Manufacturers of PV Modules has applied to MNRE for including their models and name in the List of Models and Manufacturers for Solar PV Modules empanelled by MNRE in its ALMM order, then the bidder has to submit the acknowledgement for application for the same. In such cases if the name is not included in the said list as on the date of opening of financial bids/STC meeting, then the bidders will be treated as technically non-eligible (it is the responsibility of the bidder to submit the proof of inclusion of their models and name in the said list on or before the date of opening of financial bids/STC meeting). <p>To bring contractual clarity, Bidders has to give explicit declaration that they are aware of binding provisions of the ALMM Order and the List(s) there under, while quoting the rates in the bid.</p> <ul style="list-style-type: none"> • The Potential Induced Degradation (PID) test for solar modules as per latest MNRE requirement is mandatory. • Module shall consists of Solar Cell of minimum 5 Bus Bar technology.
Open Circuit Voltage	The open circuit voltage of the PV modules under STC should be at least 21.0 Volts for 12 Volt panel

Power out put	For 320 watt system:- it will be combination of two panels , each of min 160Watt -12V The use of higher capacity modules shall be preferred.
-do-	Each PV module (IS approved) should have;- A. name of the Manufacturer B. model or type Number C. Serial Number D. Year of make E. Make in India F. HAREDA logo(laminated inside)

1. INTERFACE SOLAR CHARGE CONTROLLER:-

The systems of 320 Watt shall be for the existing inverters on 12V solar array and having single battery of 12VDC.

For example, the block diagram of 320 watt solar inverter chargers is given as under:-

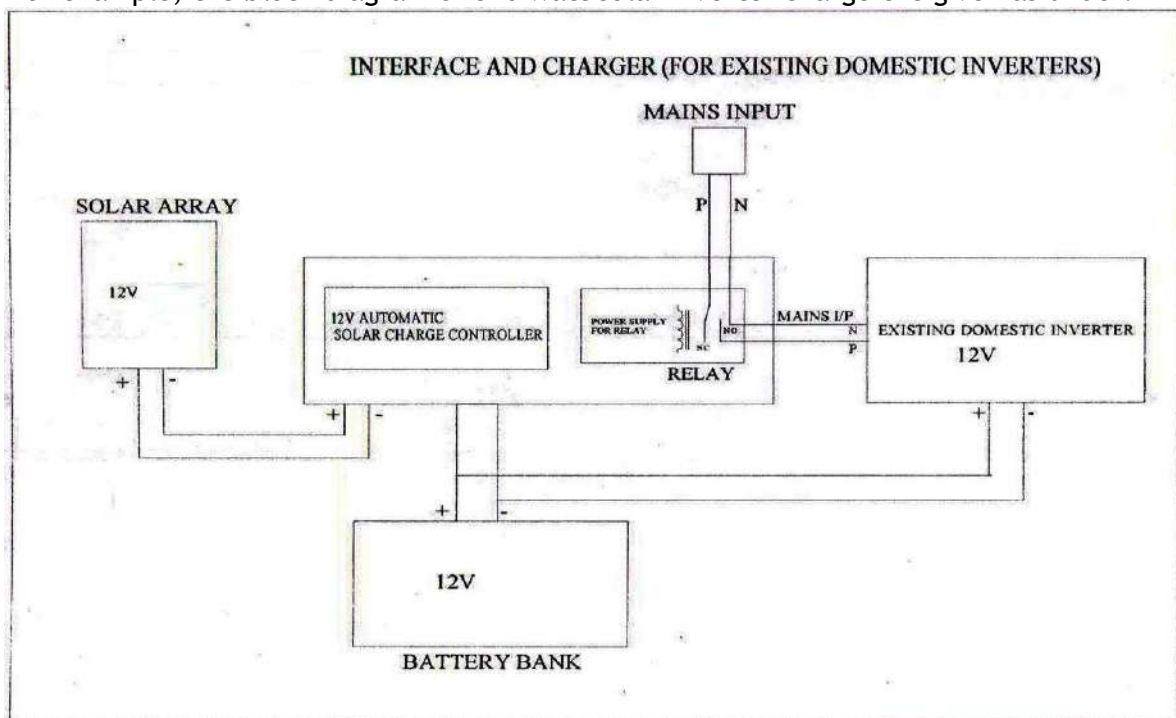

Type	The controller should be PWM type.
Current rating	It should be rated at least 20Amp. for 12V system with 320 watt solar panels.
Operation	<ol style="list-style-type: none"> In Morning condition- <ul style="list-style-type: none"> When Solar of low intensity is available and Grid is on and the battery is fully charged- Under such condition, the system should work on solar only, when solar current output reaches to 2.0 - 2.5 Amp in case of 320 watt solar inverter charger.

	<ul style="list-style-type: none"> The grid should be automatically on/off from existing inverter to support the load from battery and solar panels. When battery voltage falls below preset level and solar is available sufficiently then priority should be from solar side. <p>2. In Day time condition- The system should be designed to give priority to solar power and use grid power only when solar power is insufficient to charge the batteries and battery charge is insufficient to meet the load requirement. When batteries are fully charged during day time, the interface unit shall automatically cut off AC grid power from the system and load should run through the inverter(using stored battery charge)</p> <p>3. In evening condition- When solar power drops to 2.5-2.0 Amp in case of 320 W solar inverter chargers, the systems should be shift to Grid and becomes normal domestic inverters during night time.</p>	
Indicators	The controller should have LCD display to indicate showing of solar charging and AC charging and mains on	
Protection	Fuses should be provided to protect against short circuit conditions.	
To prevent reverse flow of current	Blocking diodes should be provided as part of the electronics, to prevent reverse flow of current through the PV module(s)	
Warrantee	The system must be warranted for five years from the date of commissioned and PV modules used in the power plant must be warranted for their output peak watt capacity, which should not be less than 90% at the end of 10 years and 80% at the end of 25 years.	
Structure for module frame	Module frame structure to be made from rail type galvanized iron with minimum 80 micron anodized structure with dimensions 40*40*40*2mm for mounting on roof of user. The module frame should be grouted in the RCC foundation columns of size atleast 150mmx150mmx150mm with concrete and cement having 4:2:1 (Minimum 4 legs in 320 watt systems)	
Wires/Cables for SPV Modules and Battery	Cables of copper conductor of multi strand wires of size 2.5mm sq in case of 320 watt solar inverter suitable for DC supply from modules to charge controller and from charge controller to batteries.	
Codes and Standards		
The components of the solar Inverter Charger must be conform to the latest edition of IEC/ equivalent BIS Standards as specified below:		
BoS item / component	Standard Description	Standard Number
Solar Modules	Crystalline silicon PV modules Conform to the latest edition	IS 14286 standards and in addition must conform to IS 61730 Part-I&II
Interface Smart Charge controller	Electronically performance test report	As per specification

Cables	General Test and Measuring Methods PVC insulated cables, UV resistant for outdoor installation	EN 50618 for DC cables
--------	---	------------------------

2. AUTHORISED TESTING LABORATORIES/CENTERS

- 2.1. The PV modules must qualify as per relevant BIS standards. Test certificates can be from any of the NABL / MNRE Accredited Testing/Calibration Laboratories.
- 2.2. Test certificates for the BOS items/components can be from any of the NABL Accredited Testing-Calibration Laboratories or MNRE approved test centers.

3. OPERATION AND MAINTENANCE MANUAL CUM WARRANTY CARD

An Operation, Instruction and Maintenance Manual cum Warrantee Card, in English and Hindi, should be provided with the Solar Inverter Charger. The following minimum details must be provided in the Manual:

- Basic principles of Photovoltaic.
- A small write-up (with a block diagram) on Solar Inverter Charger - its components, PV module,, electronics and expected performance.
- Significance of indicators
- Clear instructions about mounting of PV module(s).
- Clear instructions on regular maintenance and trouble shooting of the Solar Inverter Charger.
- DO's and DONT's.

Name and address of the contact person for repair and maint

The detailed Specifications of the Store items as mentioned in Para B of the Schedule-A/NIT are as under:-

TECHNICAL SPECIFICATIONS OF 640 WATT SOLAR CHARGERS WITH INTERFACE CHARGE CONTROLLER TO CHARGE THE BATTERIES OF EXISTING DOMESTIC INVERTORS

Item	Description
CAPACITY	640 Watt small solar power pack to charge the batteries of existing domestic inverters.
SPV Module	<ul style="list-style-type: none"> • The Photovoltaic module should be Mono/ poly crystalline. • The Photovoltaic modules must be BIS certified as per IS 14286 and in addition modules must confirm to IS/IEC 61730-1 requirement for construction and part-2 requirement for testing, for safety qualifications. The supplier shall provide performance guarantee for the PV modules used in the power plant must be warranted for their output peak watt capacity, which should not be less than 90% at the end of 10 years and 80% at the end of 25 years. • The efficiency of the PV modules should be minimum 15% and fill factor should be more than 70%. • Only indigenously produced PV modules with indigenously manufactured solar PV cells shall be allowed in PV array. The Solar Module must be comply with MNRE OM of even No. dated 02.01.2019 for enlistment under “Approved Models and Manufacturers of Solar Photovoltaic Modules (Requirement of Compulsory Registration) order, 2019 and its subsequent amendments at the time of supply. Further, the models and manufacturers of PV Modules shall be included in the List of Models and Manufacturers for Solar PV Modules empanelled by MNRE as per its ALMM order (and also valid at the time of supply of material) from time to time. • If the Manufacturers of PV Modules has applied to MNRE for including their models and name in the List of Models and Manufacturers for Solar PV Modules empanelled by MNRE in its ALMM order, then the bidder has to submit the acknowledgement for application for the same. In such cases if the name is not included in the said list as on the date of opening of financial bids/STC meeting, then the bidders will be treated as technically non-eligible (it is the responsibility of the bidder to submit the proof of inclusion of their models and name in the said list on or before the date of opening of financial bids/STC meeting). <p>To bring contractual clarity, Bidders has to give explicit declaration that they are aware of binding provisions of the ALMM Order and the List(s) there under, while quoting the rates in the bid.</p> <ul style="list-style-type: none"> • The Potential Induced Degradation (PID) test for solar modules as per latest MNRE requirement is mandatory. • Module shall consists of Solar Cell of minimum 5 Bus Bar technology.
Open Circuit Voltage	The open circuit voltage of the PV modules under STC should be at least 42 Volt for nominal 24 Volt panel

Power out put	For 640 watt system:- it will be combination of two panels , each of minimum 320Watt -24V. The use of higher capacity modules shall be preferred.
-do-	Each PV module (IS approved) should have;- a. Name of the Manufacturer b. Model or type Number c. Serial Number d. Year of make e. Make in India f. HAREDA logo(laminated inside)

2. INTERFACE SOLAR CHARGE CONTROLLER:-

The system of 640 Watt will be for the existing inverters on 24V solar array and having double batteries to form 24VDC battery bank.

For example, the block diagram of 320 watt solar inverter chargers is given as under:-

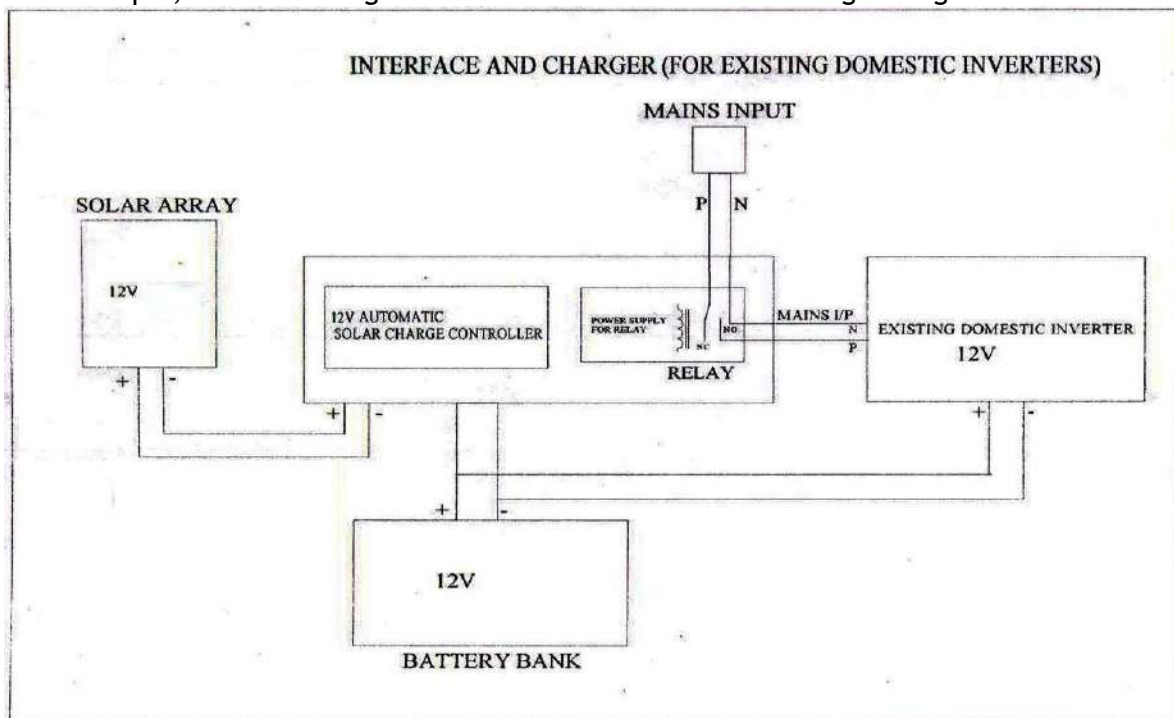

Type	The controller should be PWM type.
Current rating	It should be rated at least 40 Amp. for 24V system with 640 watt solar panels.
Operation	<p>1. In Morning condition-</p> <ul style="list-style-type: none"> When Solar of low intensity is available and Grid is on and the battery is fully charged- Under such condition, the system should work on solar only, when solar current output reaches to 2.0 - 2.5 Amp in case of 640 Watt solar inverter charger. The grid should be automatically on/off from existing inverter to support the load from battery and solar panels. When battery voltage falls below preset level and solar is available sufficiently then priority should be from solar side.

	<p>2.In Day time condition- The system should be designed to give priority to solar power and use grid power only when solar power is insufficient to charge the batteries and battery charge is insufficient to meet the load requirement. When batteries are fully charged during day time, the interface unit shall automatically cut off AC grid power from the system and load should run through the inverter(using stored battery charge)</p> <p>3.In evening condition- When solar power drops to 2.5-2.0 Amp in case of 640 watt solar inverter chargers, the systems should be shift to Grid and becomes normal domestic inverters during night time.</p>	
Indicators	The controller should have LCD display to indicate showing of solar charging and AC charging and mains on	
Protection	Fuses should be provided to protect against short circuit conditions.	
To prevent reverse flow of current	Blocking diodes should be provided as part of the electronics, to prevent reverse flow of current through the PV module(s)	
Warrantee	The system must be warranted for five years from the date of commissioned and PV modules used in the power plant must be warranted for their output peak watt capacity, which should not be less than 90% at the end of 10 years and 80% at the end of 25 years.	
Structure for module frame	Module frame structure to be made from rail type galvanized iron with minimum 80 micron anodized structure with dimensions 40*40*40*2mm for mounting on roof of user. The module frame should be grouted in the RCC foundation columns of size atleast 150mmx150mmx150mm with concrete and cement having 4:2:1 (Minimum 4 legs in 640 watt system)	
Wires/Cables for SPV Modules and Battery	Cables of copper conductor of multi strand wires of size 4.0 mm sq in case of 640 watt solar inverter suitable for DC supply from modules to charge controller and from charge controller to batteries.	
Codes and Standards		
The components of the solar Inverter Charger must be conform to the latest edition of IEC/ equivalent BIS Standards as specified below:		
BoS item / component	Standard Description	Standard Number
Solar Modules	Crystalline silicon PV modules Conform to the latest edition	IS 14286 standards and in addition must conform to IS 61730 Part-I&II
Interface Smart Charge controller	Electronically performance test report	As per specification
Cables	General Test and Measuring Methods	EN 50618 for DC cables

	PVC insulated cables, UV resistant for outdoor installation	
--	---	--

2. AUTHORISED TESTING LABORATORIES/CENTERS

- 2.1. The PV modules must qualify as per relevant BIS standards. Test certificates can be from any of the NABL / MNRE Accredited Testing/Calibration Laboratories.
- 2.2. Test certificates for the BOS items/components can be from any of the NABL Accredited Testing-Calibration Laboratories or MNRE approved test centers.

3. OPERATION AND MAINTENANCE MANUAL CUM WARRANTY CARD

An Operation, Instruction and Maintenance Manual cum Warrantee Card, in English and Hindi, should be provided with the Solar Inverter Charger. The following minimum details must be provided in the Manual:

- Basic principles of Photovoltaic.
- A small write-up (with a block diagram) on Solar Inverter Charger - its components, PV module,, electronics and expected performance.
- Significance of indicators
- Clear instructions about mounting of PV module(s).
- Clear instructions on regular maintenance and trouble shooting of the Solar Inverter Charger.
- DO's and DONT's.

Name and address of the contact person for repair and maintenance.

Technical Bid format/ Index for the Technical Bid documents

Sr. No.	Name of Document	Status of Submission (Yes/No)	Page Number as per numbering given to the technical bid documents uploaded on the portal
1	Submission of online payments i.e Earnest Money Deposit, Tender Document Fee & e - Service Fee and scanned copies of supporting documents.	Yes/ No	
2	All the documents submitted by the bidder as part of its Technical Bid are attested by the signing authority of the bidder	Yes/ No	
3	An undertaking by the bidding firm in reference to acceptance of all the terms & conditions of the Schedule-A/ EOI	Yes/ No	
4	Submit a signed copy of EOI	Yes/ No	
5	The Bidder should be either a body incorporated in India under the Companies Act, 1956 or 2013 including any amendment thereto or proprietary/partnership firm/LLP. Submit a copy of certificate of incorporation in this regards	Yes/ No	
6	Bidder should be registered manufacturer of Solar Module or solar cell to be used in the quoted item Or System Integrator If manufacturer of solar module submit a copy of BIS certification of Solar Module in his name issued alongwith Potential Induced Degradation (PID) test for solar modules as per latest MNRE requirement		
7	The bidder will submit tie-up certificate for remaining minor component i.e. Interface Solar Charge Controller from the Original manufacturer of the component along with Test report in his name issued by any of the MNRE / BIS / IEC/ NABL accredited laboratory on or after 01.04.2018. Submit:-	Yes/ No	

	<p>a. Tie-up certificate from original manufacturer;</p> <p>b. copy of Test report of Interface Solar charge Controller and wire from MNRE / BIS / IEC/ NABL accredited laboratory</p>		
8	<p>The make and test report of cable/wire must also be submitted with the bid.</p> <p>Submit a copy of Test report of cable/wire from MNRE / BIS / IEC/ NABL accredited laboratory</p>	Yes/ No	
9	<p>The manufacturing firm should have a valid ISO 9001:2015 Certificate in the field of quoted item.</p> <p>Submit a copy of valid ISO 9001:2015 Certificate</p>	Yes/ No	
10	<p>Bidder should have not been debarred/blacklisted by any Govt. Deptt's / organization/ PSU's / institutions/ agencies/ autonomous Organizations.</p> <p>Submit a Affidavit duly attested by the notary stating that the bidder have not been debarred/blacklisted by any Govt. Deptt's / organization/ PSU's / institutions/ agencies/ autonomous Organizations.</p>	Yes/ No	
11	<p>The Bidder should have valid GST registration certificate and of the billing state and PAN number.</p> <p>Submit a copy of GST no and PAN no.</p>	Yes/ No	
12	<p>The bidder should have minimum average annual turnover of Rs. 28 Cr in the last three years, ending 31st March of the previous Financial Year i.e. upto 2020-21.</p> <p>Submit last 3 years turnover certificate duly certified by Chartered Accountant</p>	Yes/ No	
13	<p>Experience and Past Performance of having successfully completed similar contracts i.e. Solar Home Light System/Solar Street Light/Solar Inverter Charger/Off Grid Solar Power plant costing not less than the amount equal to Rs. 37.34 Cr of the bid quantity during last 3 years upto last upto last date of bid submission to Govt. / Semi</p>	Yes/ No	

	Govt. Organizations duly certified by competent authority. This should be supported by work order & performance Certificate /JCR issued by Govt. Deptt./Agency. Submit documentary proof		
14	The bidder should have positive net worth in the last three years, ending 31 st March of the previous Financial Year. i.e. upto 31.03.21 Submit last 3 years Net worth certificate duly certified by Chartered Accountant.	Yes/ No	
15	Bidders should provide an undertaking that after the expiry of warranty period, they will provide necessary spare and services for the maintenance of items up to the period of additional five years. Submit undertaking in this regards.	Yes/ No	
16	The Solar Module must be comply with MNRE OM of even No. dated 02.01.2019 for enlistment under “Approved Models and Manufacturers of Solar Photovoltaic Modules (Requirement of Compulsory Registration) order, 2019 and its subsequent amendments at the time of supply. The Solar Module manufacture must give undertaking with bid that they must comply the said order while supplying solar module in said item. Bidders has to give explicit declaration that they are aware of binding provisions of the ALMM Order and the List(s) there under, while quoting the rates in the bid. Submit undertaking in this regards	Yes/ No	
17	Acceptance of warranty clause as per EOI	Yes/ No	
18	If bidder is claiming benefits under “Haryana State Public Procurement Policy for MSME -2016” vide G.O. No. 2/2/2016-4I BII(1) dated 20-10-2016 and amendment vide G.O. No. 2/2/2016-4IB-II dated 11.12.2019 which will be	Yes/ No	

	<p>applicable in respect of concessions to Haryana based MSMEs and KVIs for claiming the relevant concession/s like Tender Fee, Earnest Money Deposit (EMD), Turnover, Exemption in respect of Past Performance & Experience, Purchase Preference and Performance Security then the bidders are required to submit the requisite documents as required in said policy.</p> <p>Submit requisite Documents in this regards</p>		
--	---	--	--

INFORMATION IN SUPPORT OF MEETING ESSENTIAL ELIGIBILITY CONDITIONS REGARDING AVERAGE ANNUAL TURNOVER OF THE BIDDER IN LAST THREE FINANCIAL YEAR ENDING 31.3.2021

Annual turnover of the bidder in last three financial year:

Name of Bidder:

Annual turnover data for last three years ending on 31 st March 2021			
S.No.	Year	Turnover (Rs. In Lacs)	Turnover Rupees in words
1.	2018-19		
2.	2019-20		
3.	2020-21		
4.	Average turnover in last three years ending on 31 st March 2021 =(1+2+3)/3		

Signature with seal of bidder

Dated:

Signature of Chartered Accountant with seal

Name _____

Name of CA Company: _____

M.No. _____

Note:

1. Bidder must complete the information in this form.
2. The information provided shall be certified by Chartered Accountant.

DECLARATION BY THE BIDDER
(To be submitted on letter head of Bidder)

Reference No:

Date:

To

The Director General,
New & Renewable Energy Department,
Panchkula (Haryana),

Subject: Supply, installation and commissioning of 320/640 Watt Solar Inverter Charger in the Haryana State with five years warranty of complete system.

Madam/ Sir,

1. We have read and examined the tender documents relating to the subject cited works (hereinafter referred to as "Works") as issued by you:
2. Having examined the Tender Documents and being duly authorized we, hereby, bid for the execution, and completion of the Works referred to in the Tender Documents upon the terms and conditions contained or referred to therein and in accordance to all respects with the specifications and other details given therein.
3. 'PURCHASER' and its authorized representatives are hereby authorized to conduct any inquiries or investigations to verify the statements, documents, and information submitted in connection with this Bid, and to seek clarifications from our bankers and employers regarding any financial and technical aspects. This Bid shall also serve as authorization to any individual or authorized representative of any institution referred to in the supporting information to provide such information deemed necessary and as requested by you to verify statements and information provided in this application, such as the resources, experience, and competence of the Bidder.
4. We agree to keep this Bid open for acceptance for 180 days from the date of opening of Financial Bid, or such other extended period as may be required by you and also agree not to make any modifications in its terms and conditions of our own accord.
5. We agree if we fail to keep the validity of Bid open, as aforesaid, or we make any modification in the terms and conditions of our Bid of our own accord or after the acceptance of our Bid if we fail to execute an Agreement as prescribed in the Tender Documents or commence the execution of the works as provided in the Tender Documents, we shall become liable for forfeiture of the Earnest Money Deposit. In such an event you shall, without prejudice to any other right or remedy, be at liberty to forfeit the Earnest Money Deposit absolutely and take other actions as per terms & conditions of the contract.
6. We certify that the Bid submitted by us is strictly in accordance with the terms, conditions, specifications etc. as contained in the Tender Documents, and it is further certified that it does not contain any deviations to the aforesaid documents.
7. The bid is made with the full understanding that:-

- a) Bids by qualified bidders will be subject to verification of all information submitted for qualification at the time of bidding
 - b) PURCHASER reserves the right to:
 - (i) Amend the scope and value of any work bid under this tender.
 - (ii) Reject or accept any application, cancel the tender process and reject all bidders by giving a written notice.
8. PURCHASER shall not be liable for any actions taken under (b) i and ii above.
 9. We undertake, if our bid is accepted, and on receipt of the work order to commence the works and to complete and deliver the whole of works comprised in the contract within the period stated and in compliance with the tender documents.
 10. If our bid is accepted, we will furnish Performance Security Deposit as per terms & conditions mentioned in EOI.
 11. We understand that you are not bound to accept the lowest or any bid you may receive.
 12. All the major items like module, interface charge controller, wire etc. should be indigenously made.
 13. We are capable of executing and completing the work as required in the tender.
 14. We accept all risks and responsibilities directly or indirectly connected with the performance of the tender.
 15. We have no collusion with other Bidder, any employee of DNRE & HAREDA or with any other person or firm in the preparation of the bid.
 16. We have not been influenced by any statement or promises of DNRE &HAREDA or any of its employees, but only by the tender document.
 17. We are financially solvent and sound to execute the work.
 18. We have sufficient experience and competent to perform the contract to the satisfaction of DNRE &HAREDA.
 19. We are familiar with all general and special laws, acts, ordinances, rules and regulations of the Municipal, District, State and Central Government that may affect the work, its performance or personnel employed therein.
 20. Our company has never been debarred from similar type of work by DNRE &HAREDA and or any of the Government undertaking/Department.
 21. We assure to execute the tendered work as per specifications, terms and conditions of the contract. If awarded to us.
 22. The undersigned declare that the statements made and the information provided in the Bid including the completed applications and formats are complete, true, and correct in all aspects.

We have gone through carefully all the Bid conditions and solemnly declare that we will abide by any penal action such as disqualification or black listing or termination of contract or any other action deemed fit, taken by, the Department against us, if it is found that the statements, documents, certificates produced by us are false / fabricated.

Date of Submission:

(Signature of the Bidder)

(Seal)

Place:

DECLARATION BY THE BIDDER REGARDING QUALIFICATIONS

In relation to my/our Bid submitted to DNRE in response to their Notice Inviting Bids for empanelment of suppliers for solar inverter charger we hereby declare that:

1. I/we possess the necessary professional, technical, financial and managerial resources and competence required by the Bidding Document issued by the Procuring Entity;
2. I/we have fulfilled my/our obligation to pay such of the taxes payable to the Union and the State Government or any local authority as specified in the Bidding Document;
3. I/we are not insolvent, in receivership, bankrupt or being wound up, not have my/our affairs administered by a court or a judicial officer, not have my/our business activities suspended and not the subject of legal proceedings for any of the foregoing reasons;
4. I/we do not have, and our directors and officers not have, been convicted of any criminal offence related to my/our professional conduct or the making of false statements or misrepresentations as to my/our qualifications to enter into a procurement contract within a period of three years preceding the commencement of this procurement process, or not have been otherwise disqualified pursuant to debarment proceedings;
5. I/we do not have a conflict of interest as specified in the Act, Rules and the Bidding Document, which materially affects fair competition;

SIGNATURE OF AUTHORISED
SIGNATORY OF THE BIDDER
WITH SEAL

Date:

Name:

Designation:

Address:

GENERAL PARTICULARS OF BIDDER

Bid for Supply, installation and commissioning of 320/640 Watt Solar Inverter Charger in the Haryana State with five years warranty of complete system.

1.	Name of firm	
2.	Postal Address	
3.	Telephone, Telex, Fax No	
4.	E-mail	
5.	Website	
6.	<p>Category of Bidder/Type of Organisation The Bidder should be either a body incorporated in India under the Companies Act, 1956 or 2013 including any amendment thereto or proprietary/partnership firm/LLP. A copy of certificate of incorporation shall be furnished along with the bid in support of above.</p>	
7.	<p>Whether, the bidder (manufacturer of solar module/solar cell/ of Haryana) is any one of the following :</p> <p>(i) Manufacturing Micro & Small Enterprises (including Khadi & Village Industries) or</p> <p>(ii) Manufacturing Medium Enterprises (including Khadi & Village Industries)</p> <p><i>If, the bidder Manufacturing Small & Medium Enterprises (including Khadi & Village Industries) or Manufacturing Micro Enterprises (including Khadi & Village Industries), then please mention the device/item for which it is registered. A copy of certificate of Entrepreneurs Memorandum/UDYOG AADHAR/Odyam Registration in Haryana should be furnished along with the bid in support of above.</i></p> <p>OR System Integrator</p>	
7.1	Quality Certification of ISI/ISO/AgMark/Quality mark issued from competent authority in State or Central	

	Govt. in respect of the items/goods mentioned in the tender (Provide the required certification No. and upload the certificate with the bid).	
7.2	Is the bidder registered with DGS&D/NSIC/GOI Department/State Govt. Department/GOI PSUs/State Govt. PSUs in respect of the items/goods mentioned in the tender. (Yes/No, if yes, upload the certificate with the bid)	
7.3	If bidder is claiming benefits under “Haryana State Public Procurement Policy for MSME -2016” vide G.O. No. 2/2/2016-4I BII(1) dated 20-10-2016 and amendment vide G.O. No. 2/2/2016-4IB-II dated 11.12.2019 which will be applicable in respect of concessions to Haryana based MSMEs and KVIs for claiming the relevant concession/s like Tender Fee, Earnest Money Deposit (EMD), Turnover, Exemption in respect of Past Performance & Experience, Purchase Preference and Performance Security then the bidders are required to submit the requisite documents as required in said policy. Submit requisite Documents in this regards	
8.	Name of Directors of Company (at least Two directors with email IDs & contact Numbers)	4 (ii)
9.	Name & designation of the authorized signatory to whom reference shall be made	
10.	Present activities/business of the firm i. Module Manufacturer ii. Solar Cell Manufacturer iii. System Integrator	
11.	Registration number GST No. PAN	
12.	Place & State of billing	
13.	Have the contractor/ firm to pay arrears of income tax? If yes up to what amount?	
14.	Have the contractor/ firm/firms having common director ever been debarred by any	

	Govt. Deptt. /Public Sector Undertakings for undertaking any work?	
15.	Average annual turnover of the bidder for the last three years(Rs. in Lacs)	
16.	The bidder have positive net worth in the previous Financial Year. (Yes/No)	
17.	Experience of the bidder in supply of similar work (verified by any Govt. department/organisation)	
18.	Make(s) of Modules offered for the system: (Upload Tie up certificates)	a., b., c., d. etc.
19.	Make(s) of Interface Charger controller offered for the system: (Upload Tie up certificates)	a., b., c., d. etc.
20.	Make(s) of wire offered for the system: (Upload Tie up certificates)	a., b., c., d. Etc.
21.	Name of the any close/near relative working in New &Renewable Energy Department, Haryana or HAREDA	Name Designation Place of Posting Relationship
22.	Litigation history	
23.	Any Other Information	

We solemnly declare that we will abide by any penal action such as disqualification or black listing or termination of contract or any other action deemed fit, taken by, the Nodal agency against us, if it is found that the information, statements, documents, certificates produced by us are false / fabricated or any information is concealed therein.

Date

**(Signature of Bidder)
With SEAL**

NET WORTH

Name of bidder

Financial information in Rs. Lakhs	financial year 2018-19 (Rs. In Lakhs)	financial year 2019-20 (Rs. In Lakhs)	financial year 2020-21 (Rs. In Lakhs)
Total assets			
Current assets			
Total liabilities			
Current liabilities			
Profits before taxes			
Profits after taxes			
Net worth (Paid up share capital + reserves & surplus)			
Average Net worth for last Three Years			
Net worth is Positive or Negative			

Signature with seal of bidder

Signature with seal of
Chartered Accountant
Name:
M.No.

1. Bidder must fill in the form.

2. The statement of Net Worth is to be certified by a Chartered Accountant.

**Declaration for Comply Solar module as per ALMM compulsory
Registration order**

It is certified that *we are aware of binding provisions of the ALMM Order and the List(s) there under, while quoting the rates in the bid.*

Further, the Solar Module to be supplied will be indigenously produced with indigenously manufactured solar PV cells and comply with MNRE OM of even No. dated 02.01.2019 for enlistment under “Approved Models and Manufacturers of Solar Photovoltaic Modules (Requirement of Compulsory Registration) order, 2019 and its subsequent amendments at the time of supply. We undertake that the Solar Module will be comply the said order while supplying solar module in said item.

Date

**(Signature of Bidder)
With SEAL**

**UNDERTAKING BY MANUFACTURER OF PV MODULE/INVERTER/PCU/BATTERY
BANK
(on Non Judicial Stamp Paper of Rs. 10/-)**

I _____(Name of Authorised person) _____
(designation in the manufacturer company) on behalf of M/s. _____
_____ (Manufacturer of Solar Module), A company
incorporated under the Companies Act, 1956 etc , having its registered office at _____
_____and Factory at _____
_____ (hereafter called the Company) has given the undertaking as under:

1. M/s. _____ (System Integrator) Represented by _____ A company incorporated under the Companies Act, 1956 etc , having its registered office at _____ (hereafter called the system integrator) is hereby authorised to install the product /device.... (Solar Module) manufactured by the Company, in the State of Haryana in reference to the EOI no. invited by New & Renewable Energy Department/HAREDA for supply and installation of the Solar inverter Charger, if name of System Integrator is finalized in the rate contract and orders are received.
2. In case System Integrator defaults at any stage of execution of warrantee/guarantee/CMC and after sale service of the said device, installed in reference to empanelment of the said EOI, then the Company will be responsible to execute the warrantee/guarantee/CMC of the product/device (Solar Module) at site of installation as per the terms and conditions of empanelment of the above EOI.
3. In case System Integrator defaults, the Company will adhere the directions of the New & Renewable Energy Department/HAREDA directly.

DATED:

Sign.:
Name of Authorised person:
Designation of Auth. Person:
Name of Manufacturer Company
With seal

(Tajinder Singh)
STM

(R.S. Poonia)
Project Officer

(Sukhchain Singh)
Project Manager

Format for Price bid for Solar Inverter Chargers

Sr. No.	Description of System	Base Rate per system with warranty for five years (In Rs,)	Applicable GST (8.9%)	Total tentative rate per system with warranty for five years inclusive of GST at F.O.R sites. (In Rs.)
1.	Supply, Installation and commissioning of 320 Watt solar inverter charger with 05 year warranty			
2	Supply, installation and commissioning of 640 watt solar inverter charger with 5 years warranty			